

OVER HEAD TANK  
SCIENTIFICALLY CLOSED  
SIZE 10'0"X7'6"X5'0"

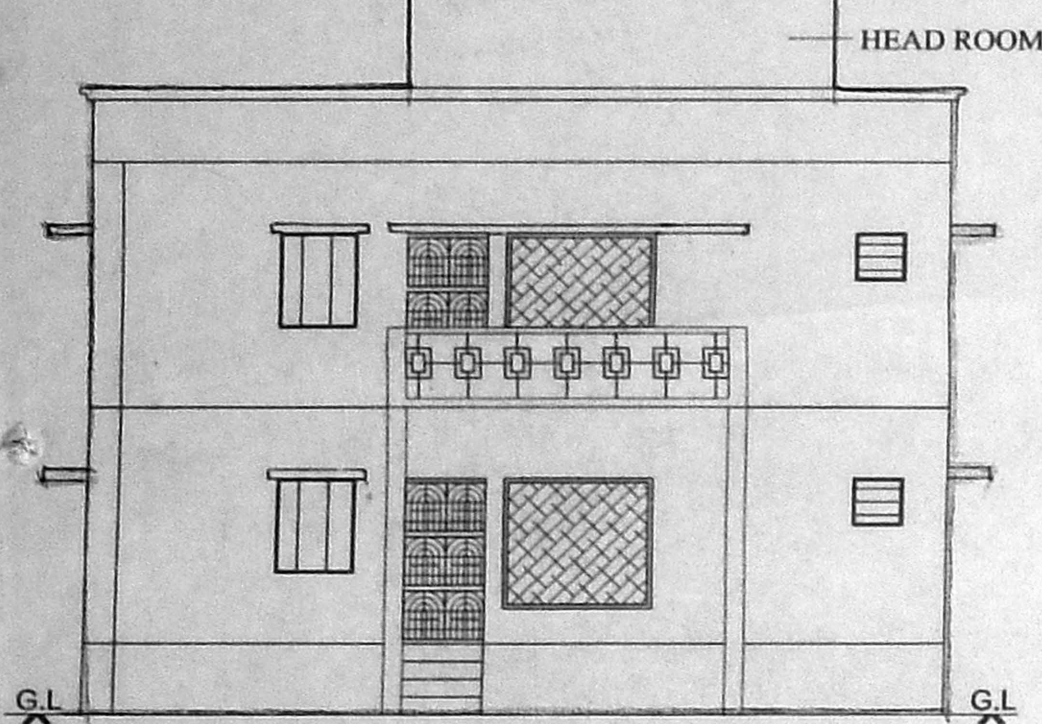

FRONT ELEVATION

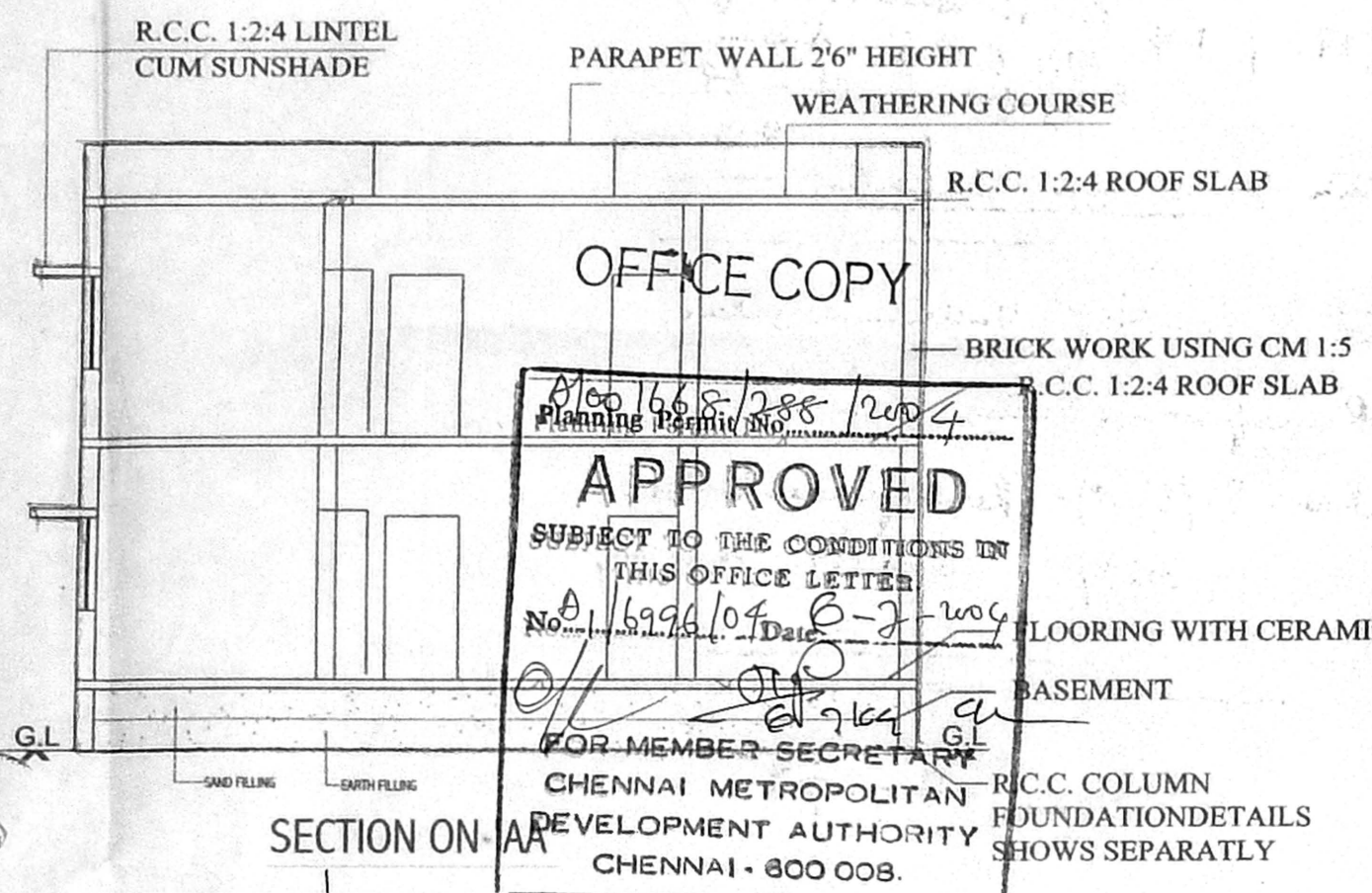

SECTION ON AA

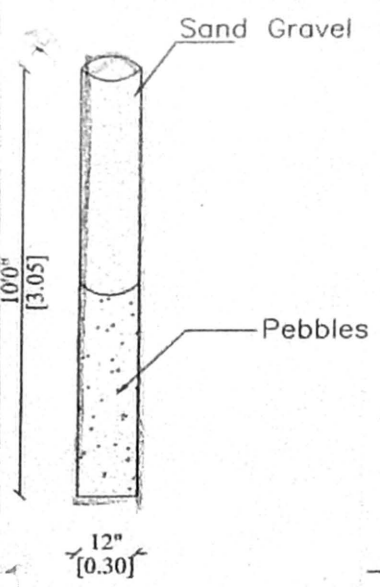

PERCOLATION PIT

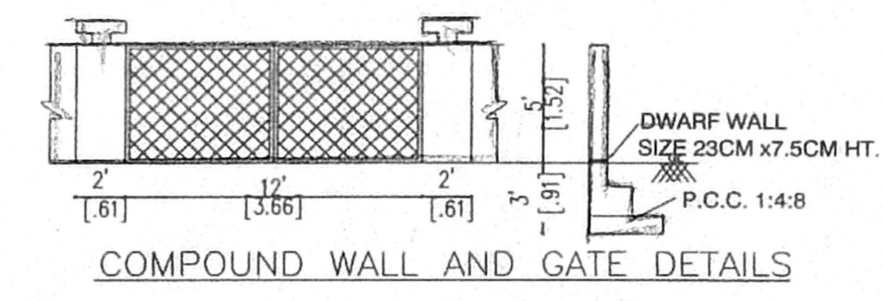

COMPOUND WALL AND GATE DETAILS

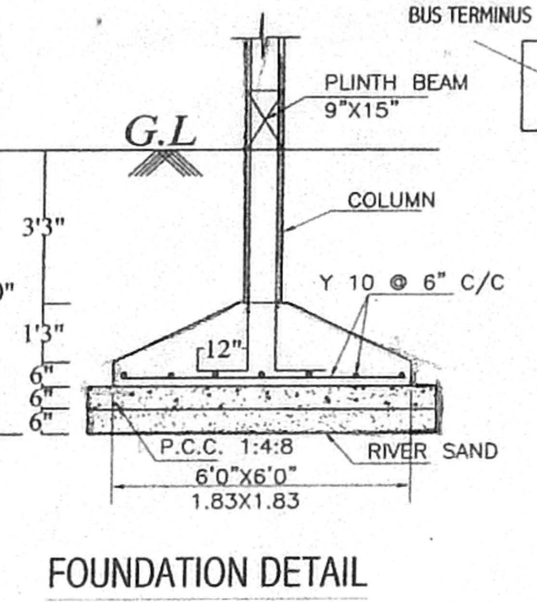

FOUNDATION DETAIL

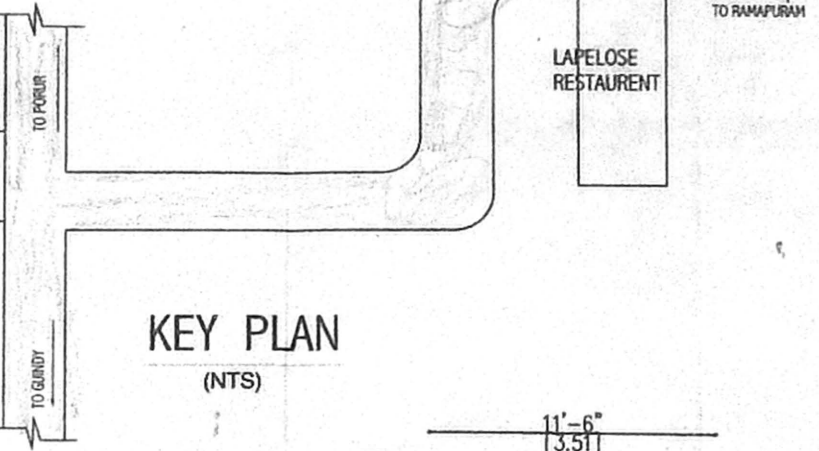

KEY PLAN (NTS)

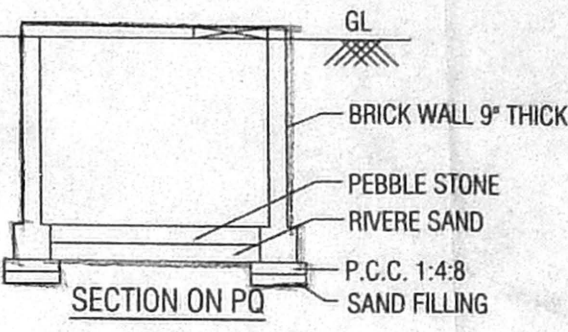
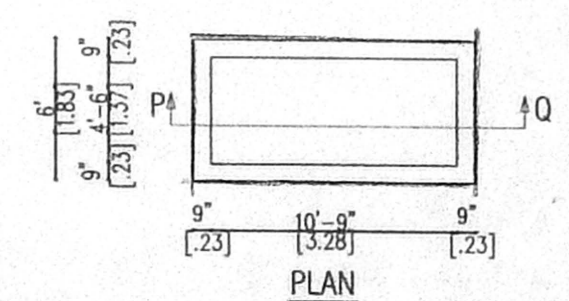

SECTION ON PQ  
COLLECTION SUMP FOR  
RAIN WATER HARVESTING  
FROM TERRACE  
(SCIENTIFICALLY SEALED)

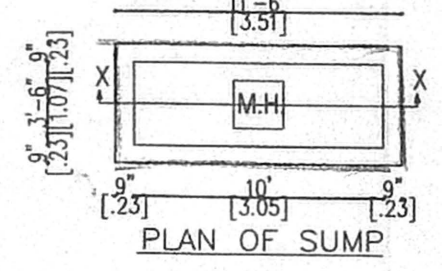

PLAN OF SUMP

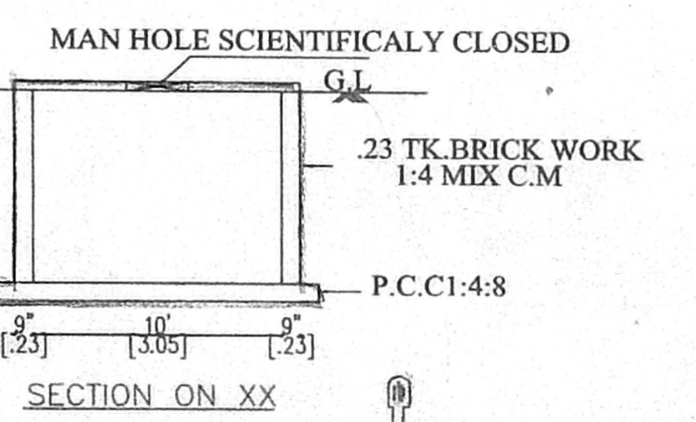

SECTION ON XX

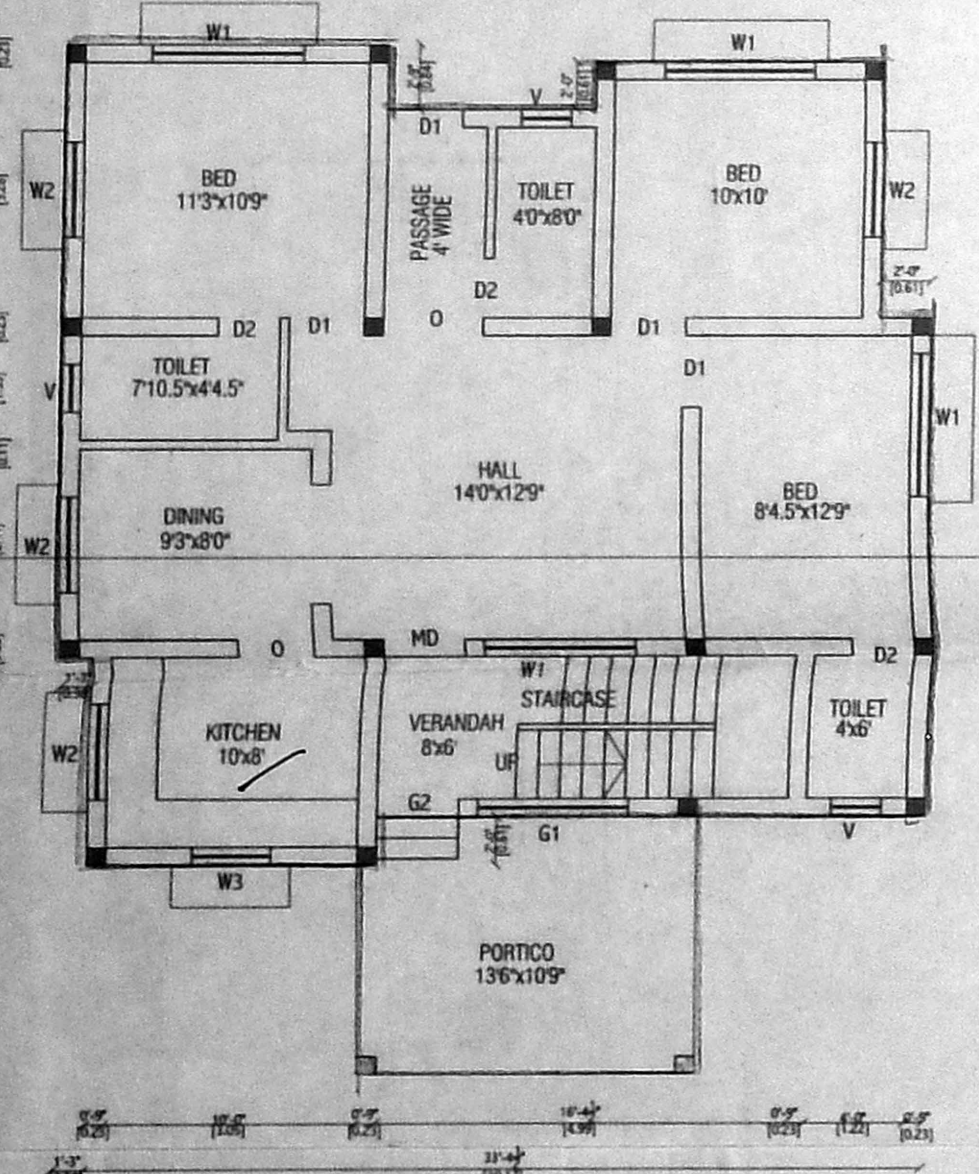

GROUND FLOOR PLAN

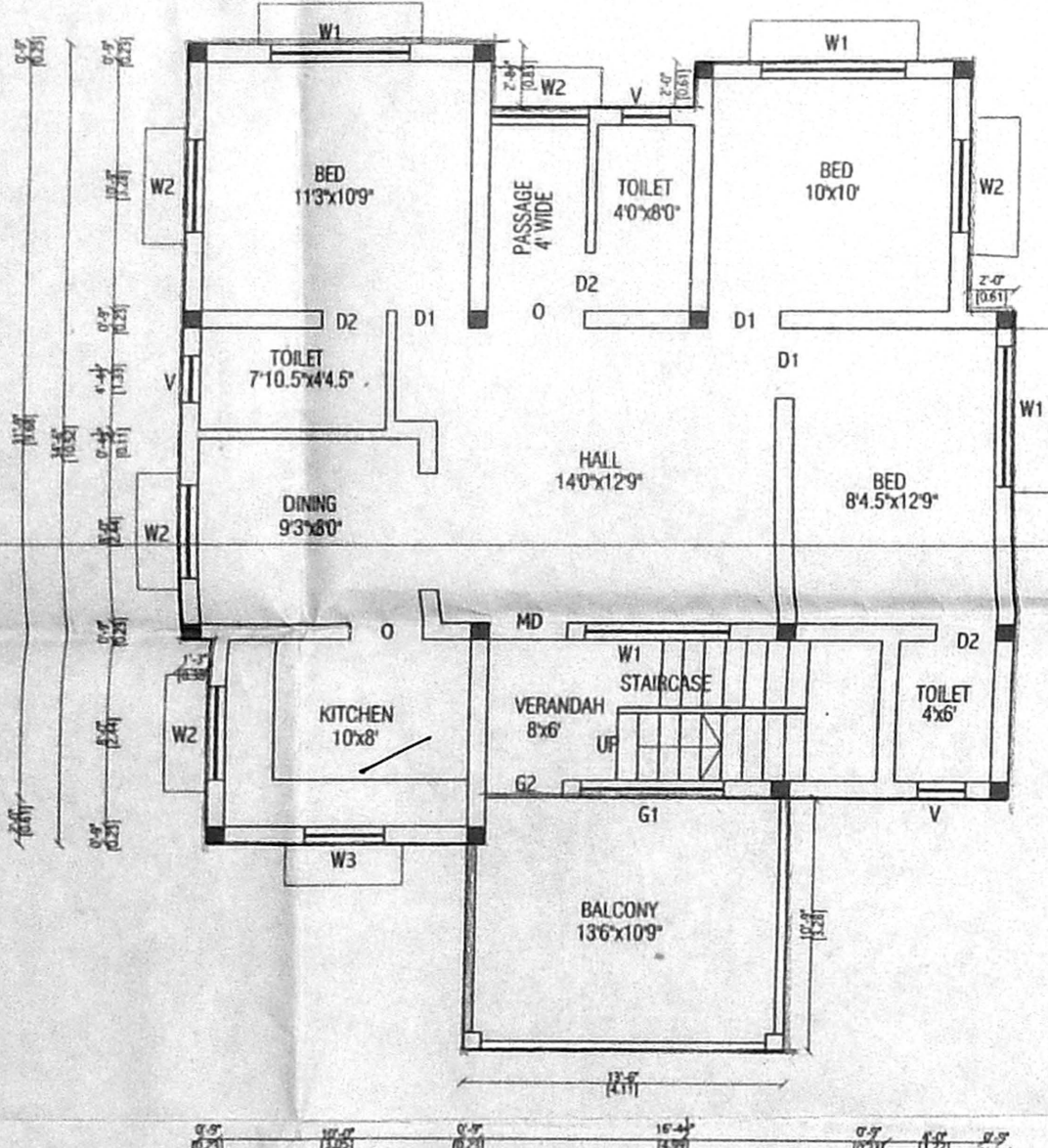

FIRST FLOOR PLAN

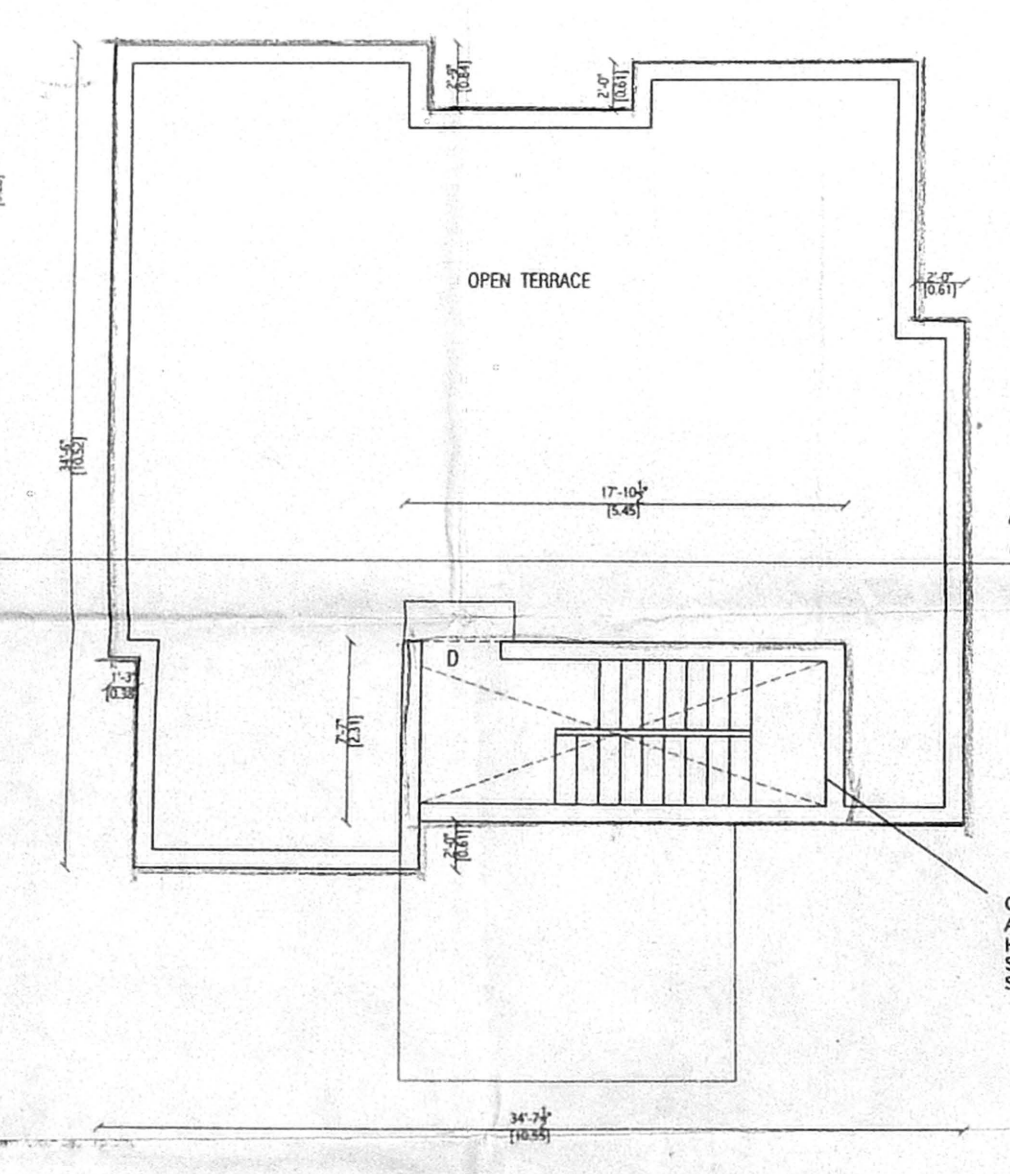

TERRACE FLOOR PLAN

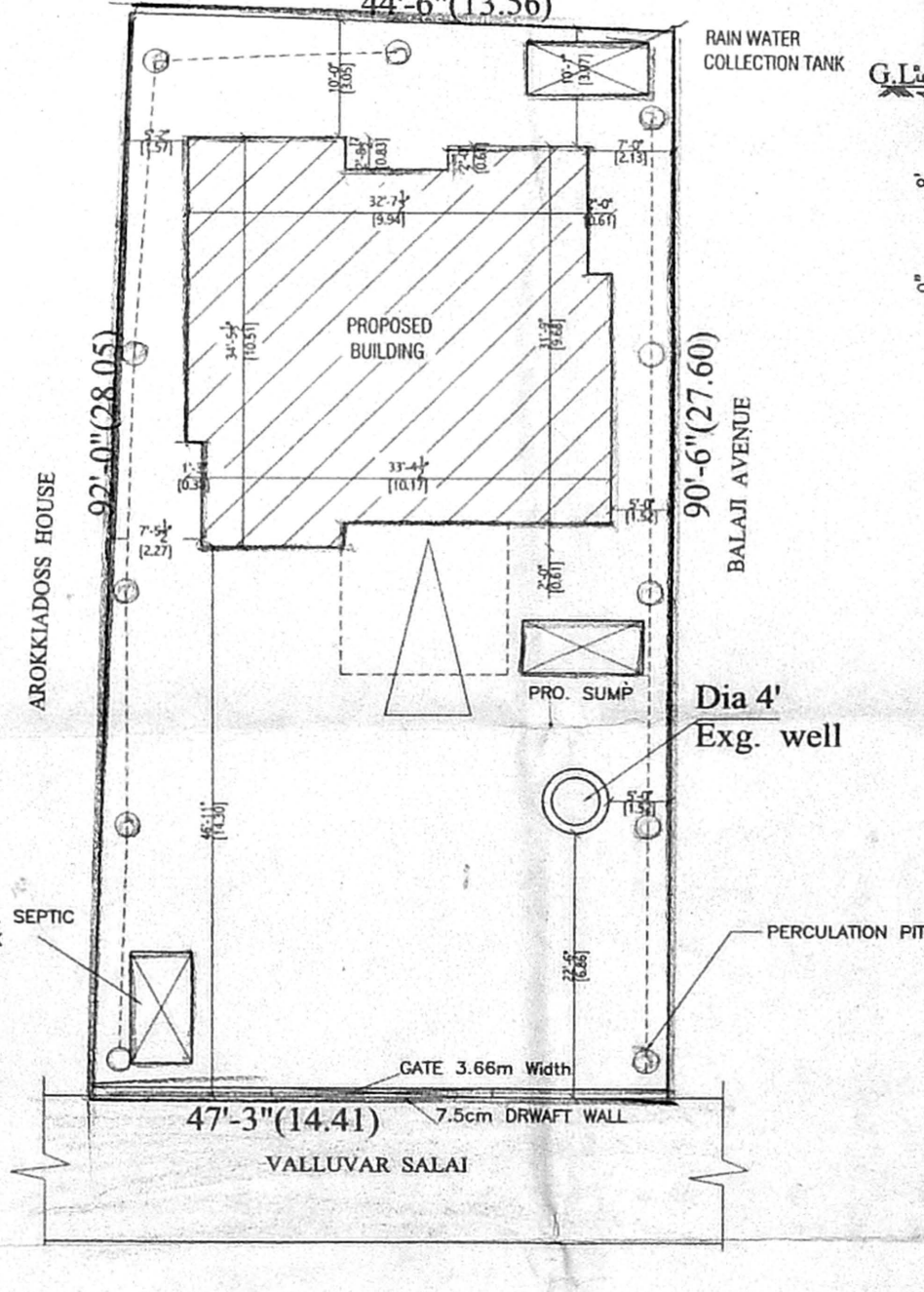

SITE PLAN  
SCALE: 1:50

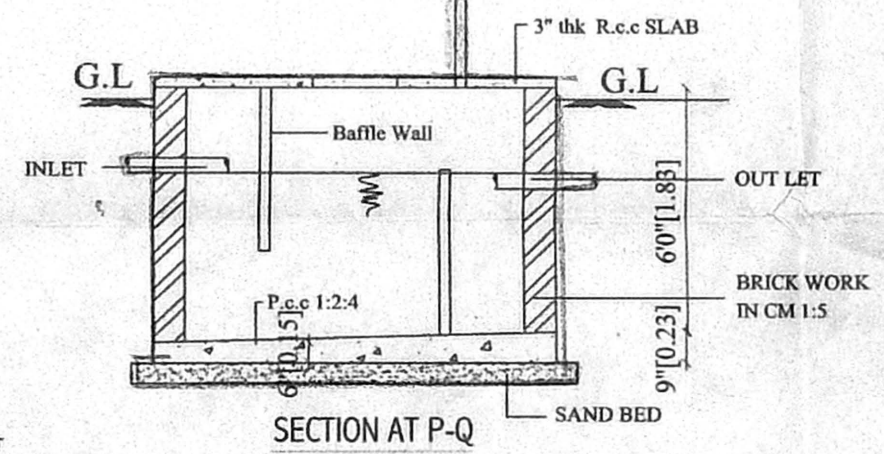

SECTION AT P-Q

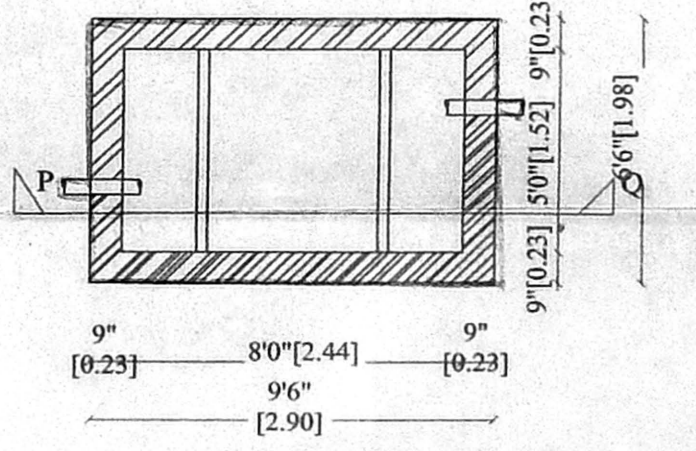

PLAN  
SEPTIC TANK

**APPROVED**  
SUBJECT TO THE CONDITIONS IN  
THIS OFFICE LETTER  
No. 16994/04 Date: 8-2-2004  
FOR MEMBER SECRETARY  
CHENNAI METROPOLITAN  
DEVELOPMENT AUTHORITY  
CHENNAI - 600 008.



**PLAN SHOWING THE PROPOSED  
RESIDENTIAL BUILDING IN S.NO. 8972A  
PART, NEW S.NO: 8975 AT  
DOOR OLD NO: 6/105, NEW NO: 6/115,  
VALLUVAR SALAI,  
RAMAPURAM VILLAGE,  
VILLIVAKKAM PANCHAYAT UNION,  
AMBATTUR TALUK,  
TIRUVALLUVAR DISTRICT.**

**SPECIFICATION:-**  
FOUNDATION IN P.C.C 1:5:10  
FLOORING IN P.C.C 1:4:8  
ROOF SLAB IN 1:2:4  
BRICK WORK IN CM 1:5  
PLASTERING IN CM 1:3

**SCHEDULE OF JOINERY:**

MD	MAIN DOOR	3'-3"x7'-0" (0.99x2.13)
D1	DOOR	3'-0"x7'-0" (0.91x2.13)
D2	DOOR	2'-6"x7'-0" (0.76x2.13)
W1	WINDOW	6'-0"x4'-6" (1.83x1.37)
W2	WINDOW	4'-0"x4'-6" (1.22x1.37)
W3	WINDOW	4'-0"x3'-6" (1.22x1.07)
G1	GRILL	6'-0"x3'-6" (1.83x1.37)
G2	GRILL GATE	3'-3"x7'-0" (0.99x2.13)
V	VENTILATOR	2'-0"x3'-0" (0.61x0.91)

AREA	SQ. FT	SQ. M
PLOT AREA (AS PER DOCUMENT)	4199.00	390.30
PLOT AREA (AS PER PATTAH)	4303.00	399.76
PRO. GROUND FLOOR	1086.72	100.96
PRO. FIRST FLOOR	1230.13	114.28
TOTAL AREA	2316.85	215.24
PLOT COVERAGE	25.88%	
F.S.I	0.55	

**REFERENCE**  
PROPOSAL  
ROAD  
BOUNDARY

SCALE:- 1"=8'0" ( 1:100)  
OWNER:- (R. AMIRTHARAJ)

S. ATHIYAMAN, B.E.  
Class-I. Licensed Surveyor - No. 192  
Corporation of Chennai  
5, Nathamuni Street, T. Nagar,  
Chennai - 17 Phone: 2815 6824  
Mobile 31038440

LICENSED SURVEYOR